

icon

TRAVERTINE



icon

TRAVERTINE

TRAVERTINE HAS ALWAYS BEEN
ONE OF THE MOST WIDELY USED
MATERIALS IN CLASSIC AND
CONTEMPORARY WORKS OF
ARCHITECTURE.
IT HAS BECOME A FAMILIAR PART
OF OUR URBAN AND RESIDENTIAL
SCENE, AND ITS TACTILE BEAUTY
HAS BECOME AN ICON OF REFINED,
ELEGANT EXCELLENCE FOR
OUTDOOR PAVINGS AND WALL
COVERINGS.



icon

TRAVERTINE

THE ICON TRAVERTINE RANGE PERFECTLY COMBINES THE HIGH TECHNICAL STANDARDS OF OUR PORCELAIN STONEWARES AND THE AESTHETIC APPEAL OF TRAVERTINES, RICH IN TEXTURED DETAILS AND DISTINCTIVE FEATURES.

ALL SURFACES ARE SUITABLE FOR HEAVY FOOT TRAFFIC AND FOR USE ON OUTDOOR PATHWAYS EXPOSED TO VERY WET CONDITIONS, MAKING THEM SUITABLE FOR ANY OPEN-AIR APPLICATION.

THE RANGE COMPRISES A NUMBER OF LOOKS AND STRUCTURES, FROM THE MORE NATURAL COLOURS, WITH SUBTLE VEIN PATTERNS, OF VEIN CUT AND CROSS CUT ITALIANO, TO THE MORE STRONGLY TEXTURED CROSS CUT PERUVIANO, WITH THE STRIKING COLOUR CONTRASTS BETWEEN BLOCKS AND THE STRONG VEINING TYPICAL OF TRAVERTINE FROM THE ANDES.



icon

TRAVERTINE



VEIN CUT

Blocks cut into slabs along the Travertine vein direction.

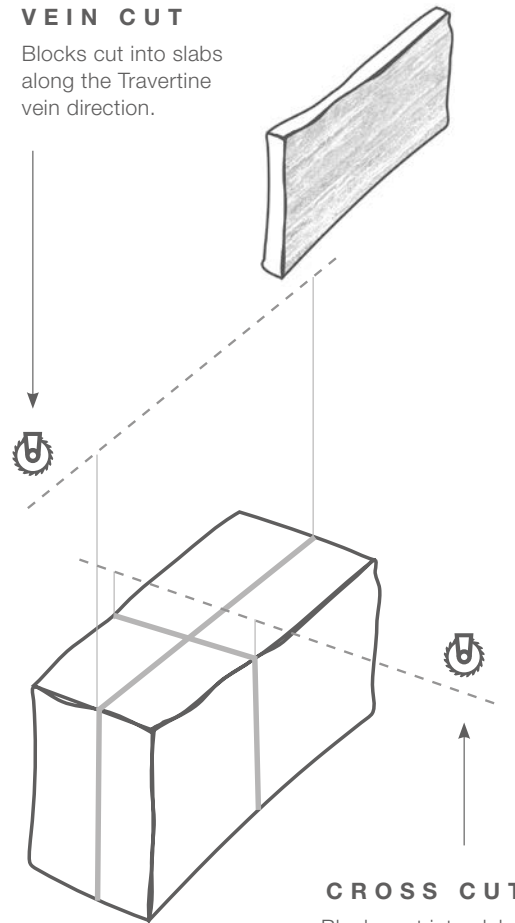

CROSS CUT

Blocks cut into slabs across the Travertine vein direction.

CROSS CUT TIVOLI'S

23 1/2" x 47 1/2"
23 1/2" x 23 1/2"
11 3/4" x 23 1/2"
11 3/4" x 11 3/4"



TIVOLI'S AVORIO



TIVOLI'S CREMA



TIVOLI'S WALNUT

CROSS CUT ANDES

23 1/2" x 47 1/2"
23 1/2" x 23 1/2"
11 3/4" x 23 1/2"
11 3/4" x 11 3/4"



ANDES SILVER



ANDES SHELL

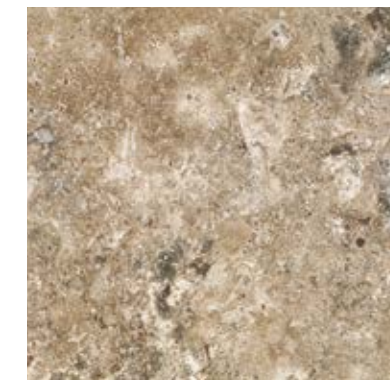

ANDES CAPPUCCINO

VEIN CUT ITALIAN

23 1/2" x 47 1/2"
23 1/2" x 23 1/2"
11 3/4" x 23 1/2"
11 3/4" x 11 3/4"



PEARL



RIVER

CROSS CUT
TIVOLI'S

FLOOR: TIVOLI'S AVORIO 23 1/2" x 23 1/2"



avorio

23 1/2" x 47 1/2"

23 1/2" x 23 1/2"

11 3/4" x 23 1/2"

11 3/4" x 11 3/4"





CROSS CUT
TIVOLI'S

avorio

V3
moderate
variation

FLOOR: TIVOLI'S AVORIO 11 7/8" x 23 1/4"



CROSS CUT
TIVOLI'S

FLOOR: TIVOLI'S CREMA 23 1/8" x 23 1/8", 11 3/4" x 23 1/8", 11 3/4" x 11 3/4"

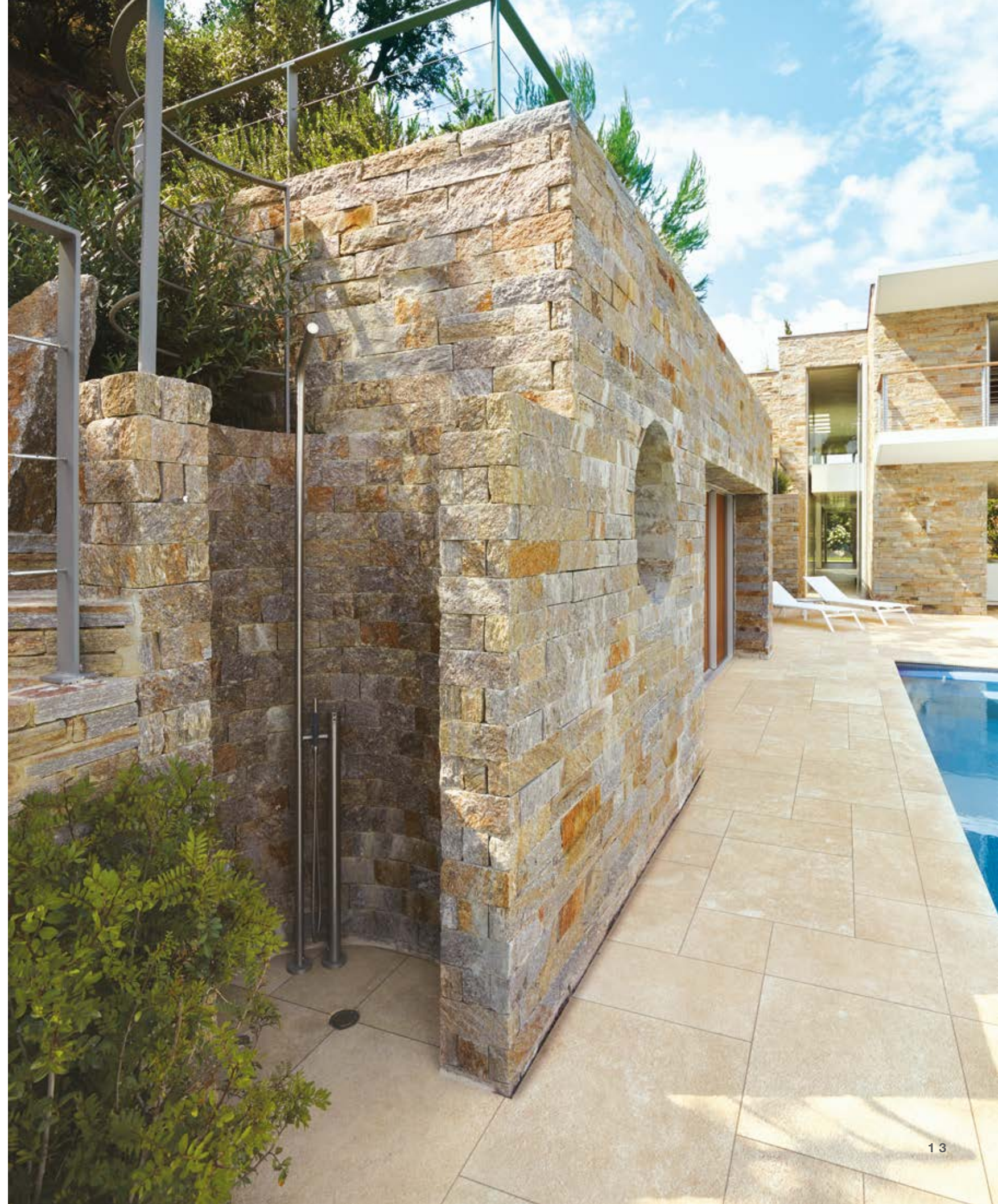





CROSS CUT
TIVOLI'S

FLOOR: TIVOLI'S WALNUT 11 $\frac{3}{4}$ "x11 $\frac{3}{4}$ "

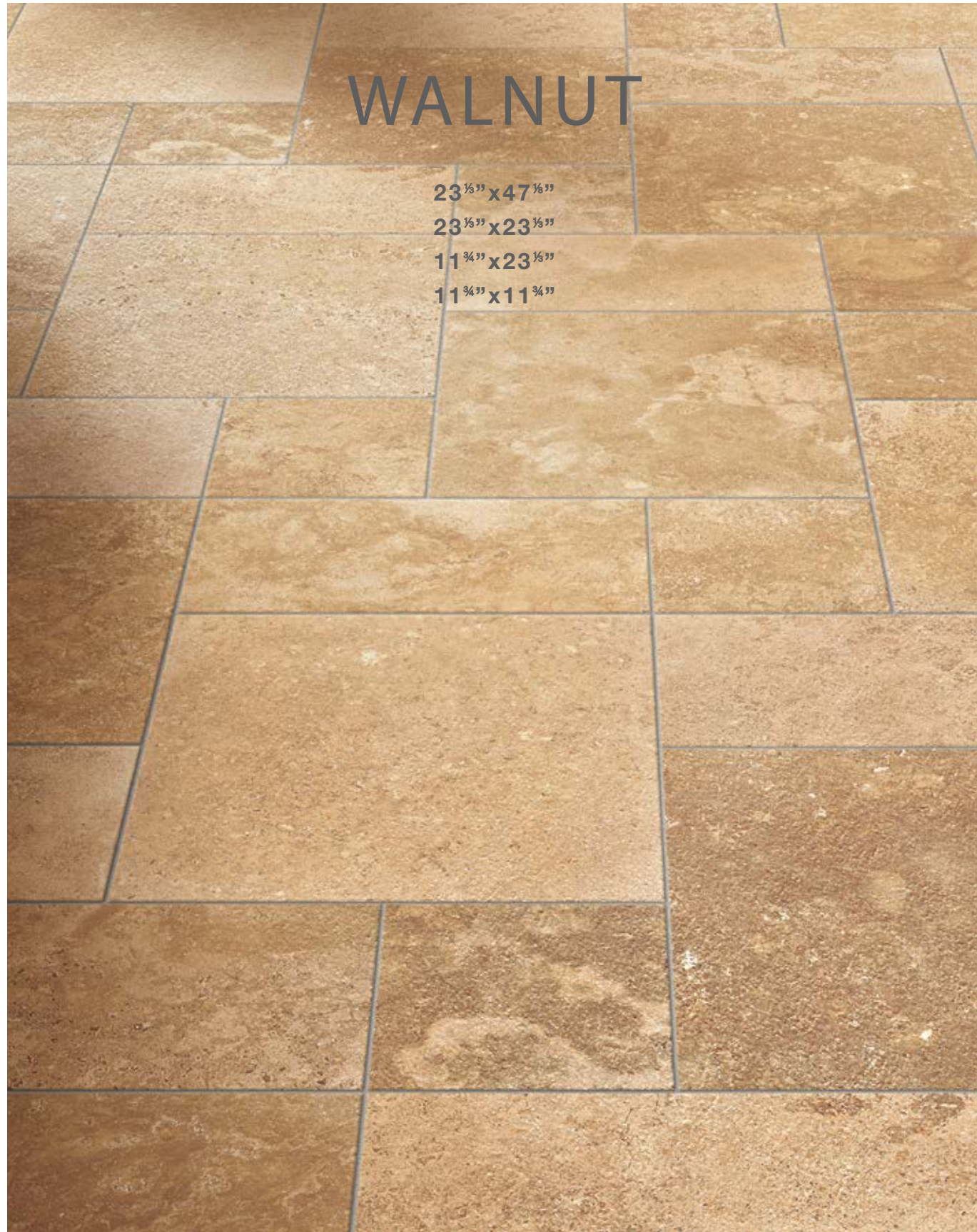

CROSS CUT
TIVOLI'S

walnut



FLOOR: TIVOLI'S WALNUT 11¾" x 11¾"



CROSS CUT
TIVOLI'S

walnut

V3
moderate
variation

FLOOR: TIVOLI'S WALNUT 23 1/8" x 23 1/8"



CROSS CUT
ANDES

FLOOR: ANDES SILVER 23 1/2" x 23 1/2"





CROSS CUT
ANDES

silver

V4
substantial
variation

FLOOR: ANDES SILVER 23 1/2"x23 1/2", 11 1/4"x23 1/2", 11 1/4"x11 1/4"



CROSS CUT
ANDES

FLOOR: ANDES SHELL 23 1/2" x 23 1/2"





CROSS CUT
ANDES

shell

V4
substantial
variation

FLOOR: ANDES SHELL 23 1/4" x 23 1/4"



CROSS CUT
ANDES

FLOOR: ANDES CAPPUCCINO 23 1/2" x 23 1/2"





CROSS CUT
ANDES

cappuccino



V4
substantial
variation

FLOOR: ANDES CAPPUCCINO 23 1/2"x23 1/2", 11 1/4"x23 1/2", 11 1/4"x11 1/4"

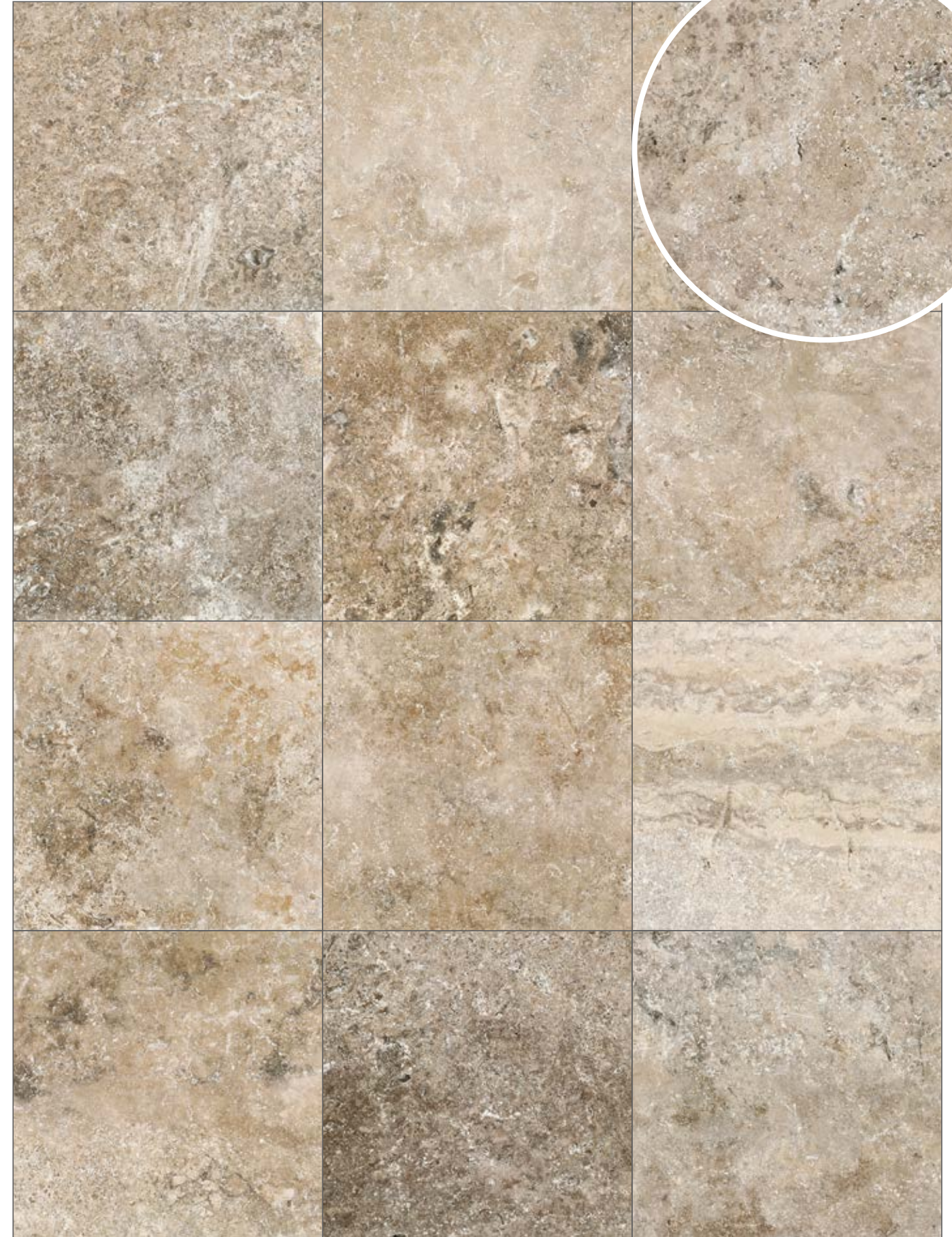

VEIN CUT
ITALIAN

FLOOR: PEARL 23½" x 47½"





VEIN CUT
ITALIAN

pearl



V2
slight
variation

WALL: PEARL 23 1/2" x 23 1/2", 11 3/4" x 23 1/2"
FLOOR: PEARL 23 1/2" x 47 1/2"



VEIN CUT
ITALIAN

FLOOR: RIVER 23 1/8" x 47 1/8"
WALKWAYS: 23 1/8" x 23 1/8"



VEIN CUT
ITALIAN

river

WALL: 23 1/8" x 23 1/8", 11 3/4" x 23 1/8", 23 1/8" x 47 1/8"

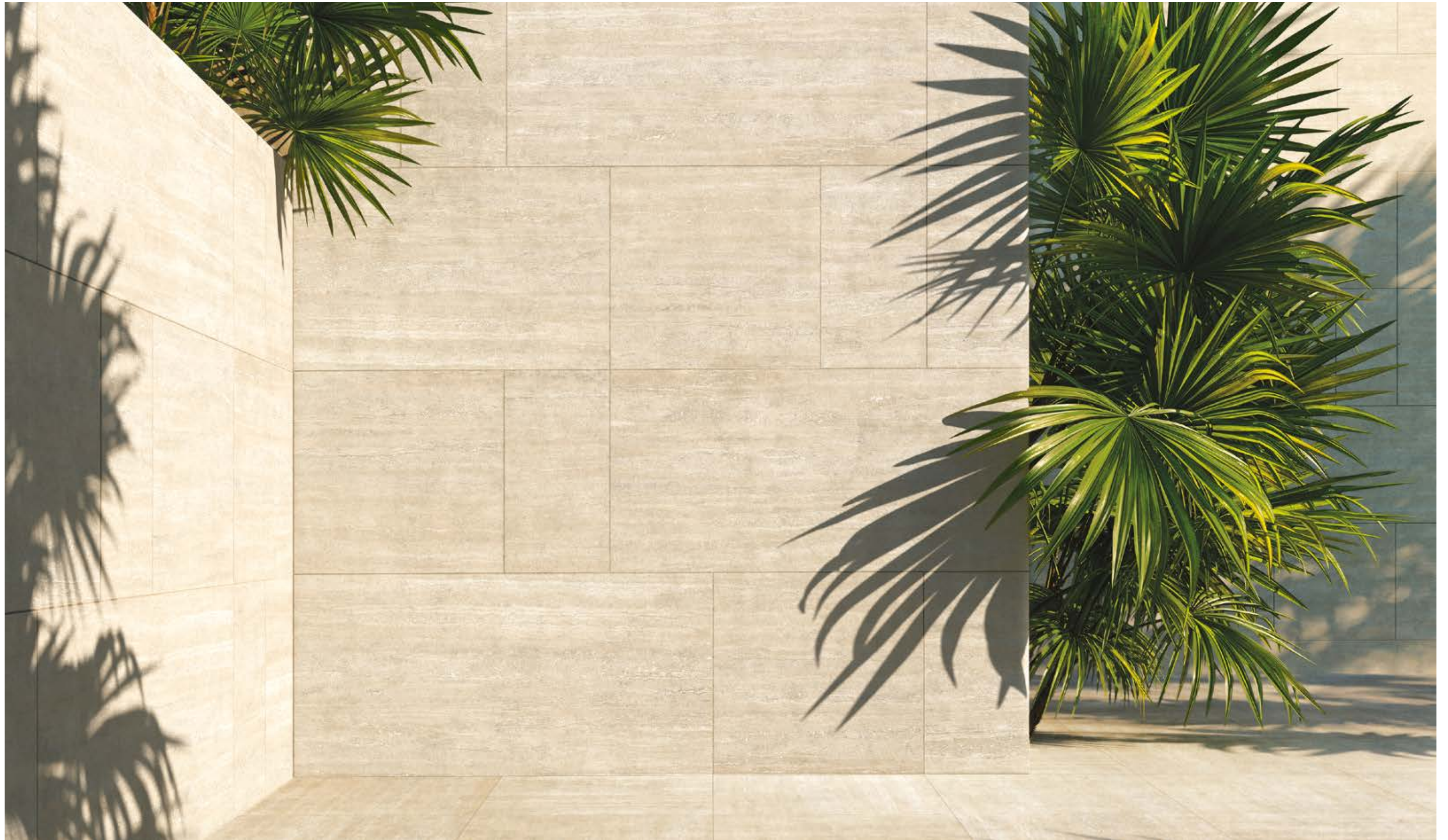

VEIN CUT
ITALIAN

river

V2
slight
variation

STAIRS AND POOL EDGE: RIVER 11 3/4" x 23 1/2"





23 1/2"x47 1/2" rectified

AVORIO US7969

CREMA US7970

WALNUT US7971



23 1/2"x23 1/2" rectified

AVORIO US7954

CREMA US7956

WALNUT US7955

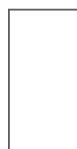

11 3/4"x23 1/2" rectified

AVORIO 1100460

CREMA 1100462

WALNUT 1100461



11 3/4"x11 3/4" rectified

AVORIO US7960

CREMA US7962

WALNUT US7961

CROSS CUT TIVOLI'S

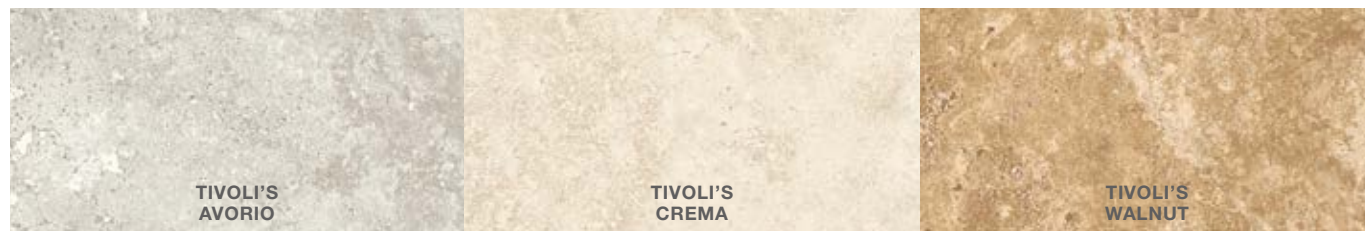

23 1/2"x47 1/2" rectified

SILVER US7966

SHELL US7967

CAPPUCCINO US7968



23 1/2"x23 1/2" rectified

SILVER US7957

SHELL US7958

CAPPUCCINO US7959

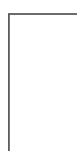

11 3/4"x23 1/2" rectified

SILVER 1100463

SHELL 1100464

CAPPUCCINO 1100465



11 3/4"x11 3/4" rectified

SILVER US7963

SHELL US7964

CAPPUCCINO US7965

CROSS CUT ANDES



23 1/2"x47 1/2" rectified

PEARL US7943

RIVER US7945



23 1/2"x23 1/2" rectified

PEARL US7908

RIVER US7909

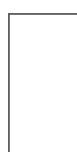

11 3/4"x23 1/2" rectified

PEARL 1100015

RIVER 1100016



11 3/4"x11 3/4" rectified

PEARL US7944

RIVER US7942

VEIN CUT ITALIAN



SHADE VARIATION

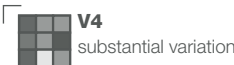
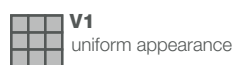

VEIN CUT
ITALIAN

CROSS CUT
TIVOLI'S

CROSS CUT
ANDES

SPECIAL PIECES

DOUBLE BEVEL COPING

11 3/4"x23 1/2"

Available in all colours.

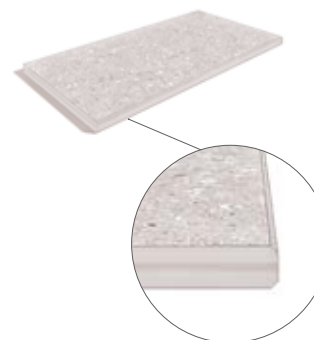

FULL BULLNOSE COPING

11 3/4"x23 1/2"

Available in all colours.



BLIND GRID

6"x24" rectified / 6"x12" rectified / 6"x6" rectified

Available in all colours.

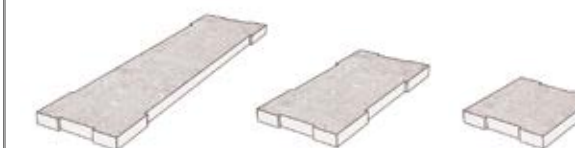

BLIND GRID ANGLE

6"x6"x12" rectified

Available in all colours.

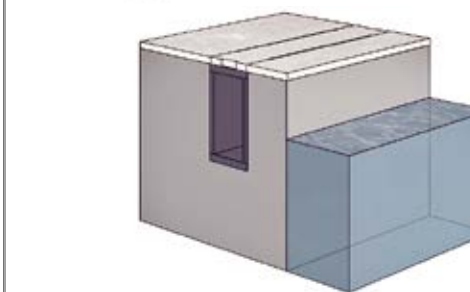
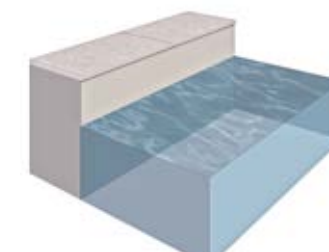
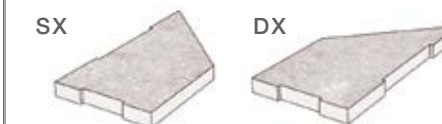

For bullnose and double bevel the actual glazed surface of color stops at the start of the radius, it shows only the body color.

PATTERNS

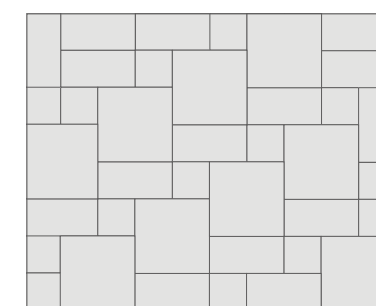

A LAYING SOLUTION

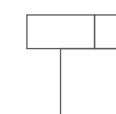

Nr. 1 pcs	23 1/2"x23 1/2"	57,2%
Nr. 1 pcs	11 3/4"x23 1/2"	28,5%
Nr. 1 pcs	11 3/4"x11 3/4"	14,3%

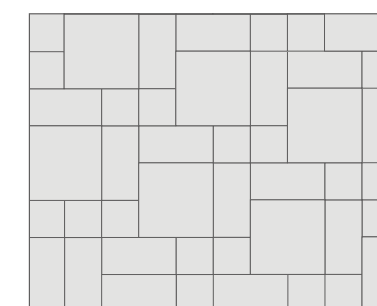

B LAYING SOLUTION

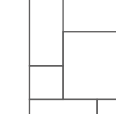

Nr. 1 pcs	23 1/2"x23 1/2"	40%
Nr. 2 pcs	11 3/4"x23 1/2"	40%
Nr. 2 pcs	11 3/4"x11 3/4"	20%

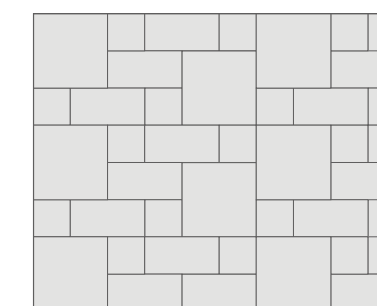

C LAYING SOLUTION

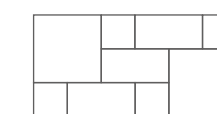

Nr. 2 pcs	23 1/2"x23 1/2"	44,5%
Nr. 3 pcs	11 3/4"x23 1/2"	33,3%
Nr. 4 pcs	11 3/4"x11 3/4"	22,2%

PACKAGING

2.0 MONOLITHIC RECTIFIED CERAMIC TILE	Thickness	Unit / Box	SqFt / Box	Boxes / Pallet	SqFt / Pallet	Weight / Box	Weight / M ²	Weight / SqFt	Weight / Pallet (included)	Pallet Size
23 1/2"x47 1/8"	3/4"	2	15,5	16	248	133,765 lb	92,90 lb	8,630 lb	2,165 lb	29"x 49"
23 1/2"x23 1/2"	3/4"	2	7.75	36	279	66,10 lb	91,80 lb	8,530 lb	2,421 lb	42"x 42"
11 3/4"x23 1/2"	3/4"	4	7,75	40	310	65,875 lb	91,50 lb	8,5 lb	2,676 lb	42"x42"
11 3/4"x11 3/4"	3/4"	5	4,85	45	218,25	41,50 lb	57,64 lb	8,55 lb	1,910 lb	42"x42"

TECHNICAL CHARACTERISTIC

STANDARS	CHARACTERISTICS OR PROPERTIES	COMPLIANCE WITH STANDARDS UNI EN 14411 G ASTM	DECLARED VALUE
ISO - 10545-3 ASTM - C 373-88	Water absorption	E <= 0.5 %	< 0.1 %
ISO - 10545-9 ASTM - C 484	Thermal shock resistance	Requested	Complies with standard
ISO - 10545-12 ASTM - C 1026	Frost resistance	Requested	Complies with standard
ISO - 10545-6 ASTM C - 1243-93	Abrasive wear	<175 mm ²	139 mm ²
ISO - 10545-2	Straightness / ASTM - C 485	+/- 0.75 % (+/- 1.8 mm)	Complies with standard
	Straightness / ISO - 10545-2	+/- 0.5 % (+/- 1.5 mm)	Complies with standard
	Thickness / ASTM - C 499	+/- 1.02 mm	Complies with standard
	Thickness / ISO - 10545-2	+/- 0.5 % (+/- 0.5 mm)	Complies with standard
	Length and width / ASTM - C 499	+/- 0.5 % (+/- 2.0 mm)	Complies with standard
	Length and width / ISO - 10545-2	+/- 0.6 % (+/- 2.0 mm)	Complies with standard
ISO - 10545-4 Bending strength in N (thickness >= 7.5 mm)	ASTM - C 648	> = 250 LBF Average	> = 225 LBF Individual
	ISO - 10545-4	> = 1300 Newton	> 13000
ASTM - C 650	Chemical resistance	As reported	Resistant
ISO 10545-14	Resistance to stain	-	5
ISO 10545-13	Chemical resistance	UB min.	UA ULA UHA
ISO 10545-8	Coefficient of linear thermal-expansion	-	$\alpha=6.3 \times 10^{-6} \text{ } ^\circ\text{C}^{-1}$
ISO 10545-5	Impact resistance	-	0.88
EN 12825	Static load	-	Centre 9.6 Kn Centre point of sides 6.5 Kn Diagonal 8.19 Kn (CLASSE 3)
	Dymanic laod capacity - hand object impact test	-	Test not passed
	Dymanic laod capacity - soft object impact test	-	Test passed
EN 1339	Bendind strength - breaking force in N	Kn 14.38	classe 14
ENV 12633	Slip resistance	> / = CL1	CL 2
DIN 51130	Slip resistance	-	R11
DIN 51097	Slip resistance	-	A + B + C min.
DM 236/89 B.C.R.A.	Slip resistance	-	> 0.40
Static coefficient of friction ASTM 1028-07 BOT 3000 Dynamic coefficient of friction (sectio n 9.6 ANSIA 137.1 2012)	Slip resistance	-	> 0.60 WET > 0.60 DRY > = 0.42
EN 13501-1	Fire resistance	-	A1 - A1 FL
* TAS 108 FLORIDA BUILDING CODE WIND UP LIFT TEST	3/4" thick 24"x24" porcelain installed on fixed height pedestals and 45° wind angle was blow of at	-	130 mph with no parapet 150 mpt with 12" high parapet



Kronos Usa Inc.
300 International Blvd.
Clarksville, TN 37040 USA
customer.service@kronos-usa.com
www.kronos-usa.com

Logistics Branch
1045 Progress Drive
Clarksville, TN 37040 USA
931.919.4861
logistic@kronos-usa.com

